

User's Guide

Model: EX30000



Parts checklist

Your telephone package includes the items shown below.



Handset

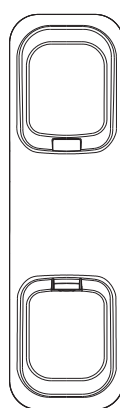

Base

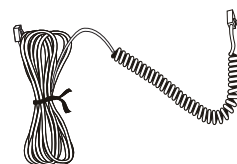

Telephone line cord



User's guide

Installing on a wall

1. Rotate the base until the engraved text "TOP" on the bottom of the base is correctly oriented.
2. Hold the straight end of the line cord so that about 2 inches of cord is available to plug into jack. Then route the remaining cord through the grooves under the base and wrap the excess cord around the posts on the back of the base as shown in figure 3.
3. Wrap the cord until reaching the coiled end and route the cord through the slot at the bottom of the base.
4. Plug the line cord into the wall jack. Slip the mounting holes on the base over the wall plate posts and firmly slide the unit down into place as shown in figure 3 below.
5. Plug the coiled end of the line cord into the handset.
6. Place the handset onto the base. Check installation by picking up handset to check for dial tone.

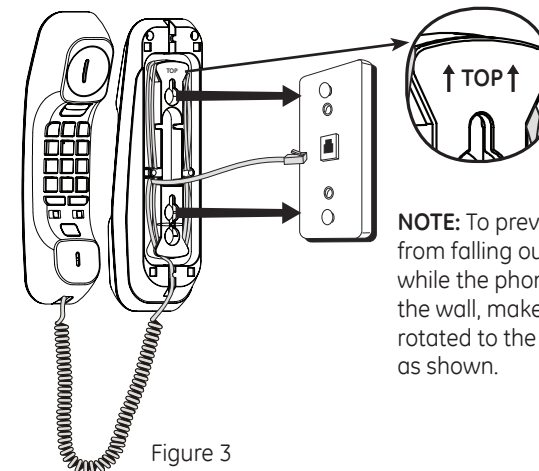

NOTE: To prevent the handset from falling out of the cradle while the phone is hanging on the wall, make sure the base is rotated to the correct position as shown.

SLIMLINE CORDED PHONE



1

3

Before You Begin

Telephone Jack Requirements

To use this phone, you need an RJ11C type modular telephone jack installed. If you do not have a modular jack, call your telephone service provider to find out how to have one installed. If you have DSL high speed Internet service, a DSL filter is required (not included). Contact your DSL service provider for more information about DSL filters.

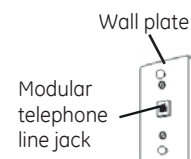

Telephone installation

Installing on a desk or table

1. Plug the telephone line cord ending with the coiled part into the jack at the bottom of the handset.
2. Plug the other end of the telephone line cord into a modular wall plate (not included) as shown in figure 1 below.
3. Store the excess telephone line cord in the grooves under the base as shown in figure 2 below.
4. Position the base with the larger end facing up as shown in figure 1 below.
5. Place the handset onto the base.

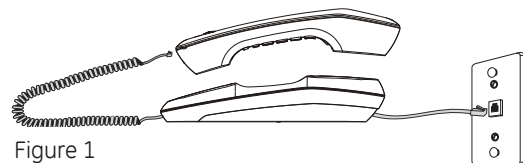

Figure 1

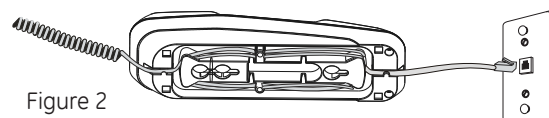
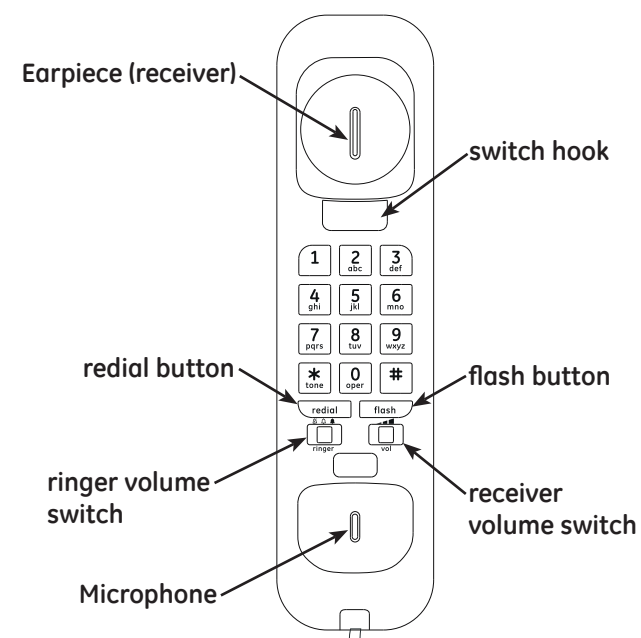

Figure 2

Handset Layout



visit our website

www.thehomephones.com



2

4

Telephone Operation

Make a call

1. Lift the handset from the base.
2. Dial the number.
3. Return the handset to the base to hang up.

Answer a call

1. Lift the handset from the base when the telephone rings.
2. Return the handset to the base to hang up.

Redial



Lift the handset and then press redial to call the last dialed number (maximum of 32 digits).

Flash

Press the **flash** button to use custom calling services such as call waiting or call transfer. Custom calling services are provided by your telephone service provider.

Receiver Volume

The listening volume can be adjusted to 3 different levels by adjusting the receiver volume switch.

-  = low
-  = medium
-  = high

Ringer Volume

The ringer volume can be adjusted to 3 different levels by adjusting the ringer volume switch.

-  = silent
-  = low
-  = high

5

Troubleshooting Tips

Problem	Cause/solution
No dial tone.	<ul style="list-style-type: none"> • Check installation: make sure the telephone line cord is connected to the handset and a modular phone jack (RJ-11). • Try disconnecting and reconnecting the line cord into the handset to ensure proper connection. • You must have touch-tone service on your line to use this phone. If you do not know what type of service you have, check with your telephone service provider. • Unplug the telephone line cord, wait for 30 seconds, and plug the phone back in. • Connect another phone to the same modular jack; if the second phone does not work, the problem might be with your wiring or local service. • Place the handset on the base for at least 20 seconds.
Phone does not ring.	<ul style="list-style-type: none"> • Make sure the ringer volume switch is not set to silent. • You may have too many extension phones on your line. Unplug some extension phones. • Check for a dial tone. If there is no dial tone, see solutions for No dial tone.

6

Problem	Cause/solution
Cannot be heard by other party.	<ul style="list-style-type: none"> • Make sure the telephone line cord is securely plugged in. • Make sure extension phones are not in use at the same time you are using the phone. It is normal for the volume to drop when additional extension phones are used at the same time.

General Product Care

- Avoid placing the phone near heating appliances and devices that generate electrical noise (for example, motors or fluorescent lamps).
- Avoid dropping the phone and other rough treatment.
- Clean the phone with a soft cloth.
- Never use strong cleaning agents, paint thinner, abrasive powder, alcohol, or other chemical products to clean the unit.
- Retain the original packaging in case you need to ship the phone at a later date.
- DO NOT expose to direct sunlight or moisture.

 **CAUTION: Disconnect the phone cord from the wall outlet before installing or replacing the batteries.**



- Never install telephone wiring during a lightning storm.
- Never touch un-insulated telephone wires or terminals, unless the telephone line has been disconnected at the network interface.
- Install or modify telephone lines with caution.
- Never install a telephone in a wet or damp location.

7

Environment

Used equipment must be disposed of in compliance with current environmental protection regulations. You should return it to you reseller or dispose of it in an approved recycling center.

WARNING: TO PREVENT FIRE OR ELECTRICAL SHOCK HAZARD, DO NOT EXPOSE THIS PRODUCT TO RAIN OR MOISTURE.

	CAUTION RISK OF ELECTRICAL SHOCK, DO NOT OPEN	
THE LIGHTNING FLASH AND ARROW HEAD WITHIN THE TRIANGLE IS A WARNING SIGN ALERTING YOU OF "DANGEROUS VOLTAGE" INSIDE THE PRODUCT.	CAUTION: TO REDUCE THE RISK OF ELECTRICAL SHOCK, DO NOT REMOVE COVER (OR BACK). NO USER SERVICEABLE PARTS INSIDE. REFER SERVICING TO QUALIFIED SERVICE PERSONNEL.	THE EXCLAMATION POINT WITHIN THE TRIANGLE IS A WARNING SIGN ALERTING YOU OF IMPORTANT INSTRUCTIONS ACCOMPANYING THE PRODUCT.

8